

Breathing Innovation
into Ventilation!



EVO-POOL



aera.com.tr



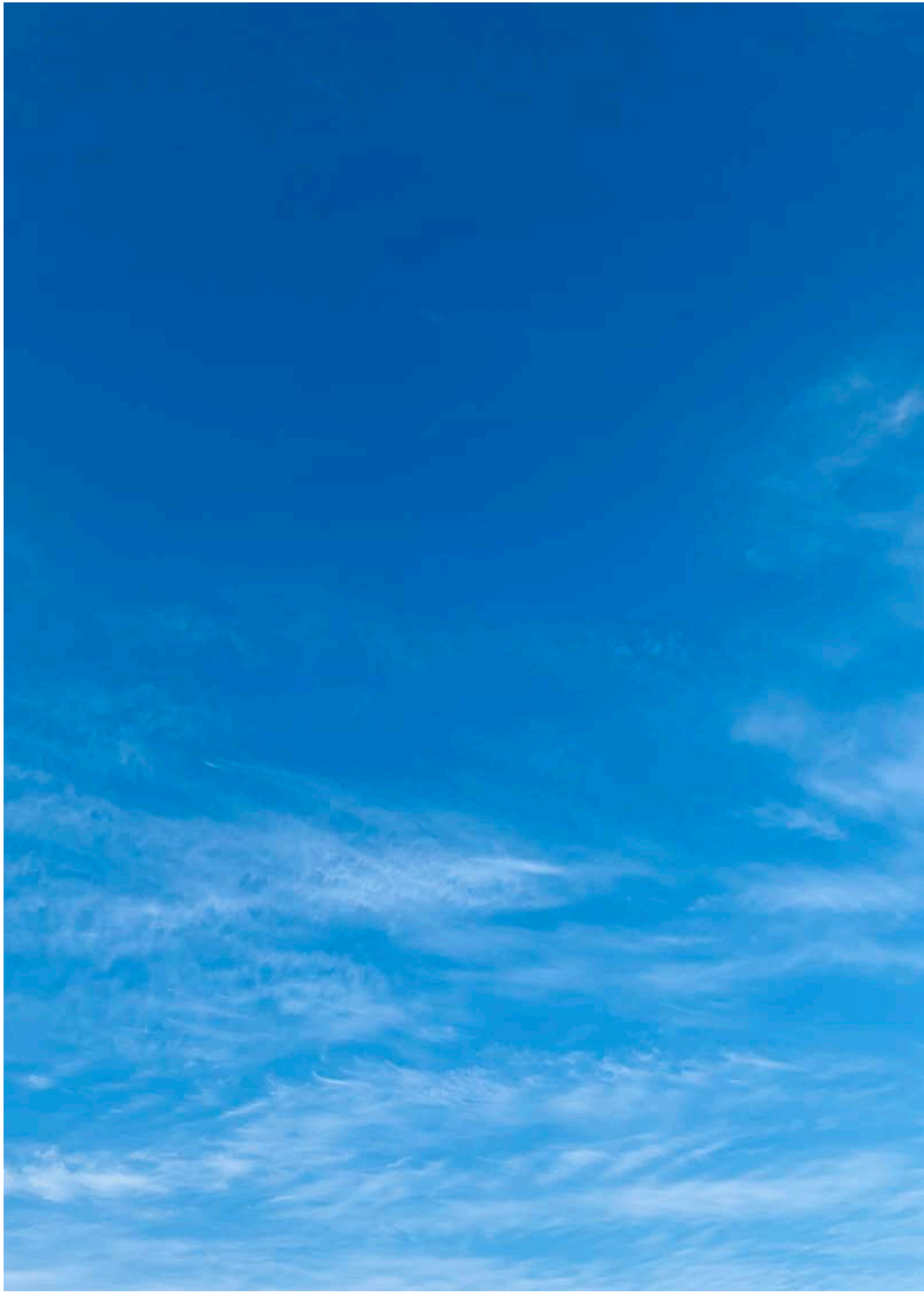

INDEX

ABOUT US.....Page 4-7

ANEMO Test Lab.....Page 8-9

CERTIFICATION.....Page 10-11

EVO-POOL.....Page 12-39

AERA is wherever you breathe fresh!

- Offices
- Restaurants
- Hotels
- Cafes
- Shopping Malls
- Exhibition Halls
- Industrial Buildings
- Museums
- Laboratories
- Markets
- Hospitals
- Malls
- Nursing Homes
- Schools and Universities
- Conference Halls
- Stadiums and Sports Halls
- Concert Halls
- Stations and Airports
- Banks



Inspiring Confidence, Powering Progress Globally

AERA products have achieved a global presence, captivating markets across Europe, the Middle East, and beyond.





Welcome to AERA



Breathing Innovation into Ventilation!

Born in the innovative surroundings of the Bilimpark – Science and Technology Development Zone, AERA started with a dedicated Product Development Team with a simple mission: to enhance air quality everywhere.

2016 In 2016, we moved to our foundational facility in Pancar Industrial Zone. Covering over 3,000 m2, this space is equipped with modern machinery, ensuring our products meet the highest standards and reach you efficiently.

That same year, we established our domestic sales office in Istanbul, marking our commitment to serve both local and international customers.

2017 was a pivotal year for us as we introduced our Modular Air Handling Units and Heat Recovery Ventilators to the market. By mid-2017, we began our journey towards achieving international certifications, ensuring our solutions stand up to global standards.

By the close of 2017, AERA broadened its portfolio with the introduction of the Compact Air Handling Units family. This range catered to diverse needs, including horizontal units for ceiling mounting and versatile standing units, both with plate and rotary heat recovery options.



Our commitment to innovation didn't stop there. In collaboration with a leading AHU Control Components manufacturer, we co-developed distinctive air handling unit controls. These state-of-the-art controls, conceived and crafted through international expertise, made their debut in the market the very same year.

2018 Recognizing the burgeoning industry demand and our ever-growing aspirations, 2018 was a significant milestone: We acquired a spacious factory land spanning 10,000 m2, setting the stage for further advancements and the promise of bringing even more refined ventilation solutions to our valued clientele.

The journey of AERA has always been marked by innovation and collaboration. A testament to this is our pioneering partnership with TUBITAK (Turkey's Scientific and Technological Research Council). This collaboration bore fruit in the form of our first government-subsidized development project. Our unique product designs further paved the way for us to receive State Funds, establishing our R&D Centre of Excellence.

Our commitment to excellence was recognized globally in 2018 when EUROVENT certified our modular AHU range. This acknowledgment, particularly for outstanding casing performance (T2/TB2, EN 1886), set us apart. That year, our drive for innovation continued unabated, with the inception of development projects centered around panel casing design and ceiling-mounted air handling units equipped with rotary wheels.

AERA's name has grown to resonate powerfully, both within Turkish borders and beyond.

Our distinction lies not just in our products but also in our unparalleled service offerings. This has enabled us to stand tall, often being the preferred choice over renowned competitors for state-of-the-art design projects.

2021 In a pivotal move at the end of 2021, we saw the completion of our new production plant. This state-of-the-art facility now houses the majority of our production activities and operational offices, reflecting our relentless pursuit of growth and excellence.

2023 In the quest for healthier indoor spaces, we've made a major stride!

We are proud to announce a significant achievement in our commitment to quality and health: our Air Handling Units have earned the **Hygienic Certificate from TÜV SÜD.**



With AERA, it's always about bringing cleaner, fresher air to spaces everywhere. We're here to serve, innovate, and grow alongside our community. AERA started with a dedicated Product Development Team with a simple mission: to enhance air quality everywhere.



Reference Standards

- EN 308
- EN 1886
- EN 13053
- EN 13779
- EU No 1253/2014 ECO-DESIGN
- EN 305
- ISO 5167-4:2003



ANEMO AERA, committed to creating energy-efficient ventilation products, has developed its products in alignment with market expectations and demands. They have implemented robust quality management and quality control systems to ensure sustainability. Beginning with customer relationship management, we have made our management philosophy traceable, measurable and transparent, including design, procurement, production and after-sales services. Internal trainings and preventive activities are performed by evaluating the harvested data and are delivered as a part of our continuous improvement policy. At AERA, every product we manufacture undergoes rigorous quality control processes, starting from the component level, and is carefully monitored at every stage of production. The air handling units undergo testing and certification by independent organizations. Additionally, tests are conducted at the ANEMO laboratory in accordance with European norms and directives, guaranteeing consistent product quality.

Testing what is produced not only allows us to understand the quality of the existing product but also ensures the continuous improvement of future products.

Intensive quality control

At AERA, our commitment to quality is unwavering and central to our operations. We believe in delivering nothing less than the best to our valued customers. To achieve this, we implement a rigorous 100% quality control inspection on all our finished goods, ensuring that every product meets the highest standards. Recognizing the criticality of each stage in the assembly process, we've instituted a comprehensive checklist for pre-assembly processes. Every assembled part is meticulously checked before it progresses to the subsequent station, ensuring accuracy and excellence at every juncture. By continually monitoring and recording quality data, we gain invaluable insights into our strengths and areas that require enhancement. This approach not only aligns with the best practices of the HVAC industry but also sets a benchmark, reinforcing our constant endeavor to ensure that every product delivered to our customers is of the highest quality possible.

ECO DESIGN All manufacturers are legally obliged to follow ECO-DESIGN directives, which are a set of the European Union's regulations that state use of energy for energy-consuming products. LOT6 of the directive reviews the ventilation devices and air handling units and is effective in the European Parliament with the EU directive number 1253/2014 and 1254/2014. The ECO-DESIGN directives, prepared by the European Council for the purpose of replacing low energy-efficient products in the market with those of high efficiency, have been accepted as a prerequisite for CE marking with the dates specified and the entry of nonconforming devices into EU countries is prohibited. Within the scope of the ECO-DESIGN directive, which has been in force since January 1st 2016, a number of sub-limit values have been defined for air handling units, such as fan, heat recovery exchanger and filter efficiency. Thermal by-pass and visual monitoring of filter arresstance has become compulsory with the directive also.

All air handling units produced at AERA are designed and manufactured according to ECODESIGN criteria



“Sustainability is no longer about doing less harm. It’s about doing more good .”

Jochen Zeitz



EUROVENT CERTIFICATION

Companies operating in the ventilation and air conditioning industry established the EUROVENT association and subsequently the association's certification body, Eurovent Certita Certification, to ensure that the performance of the units they produce can be evaluated based on common criteria, independent of local standards of countries. Today, with over 1000 members and offices in many parts of the world, EUROVENT is responsible for the certification and listing of many HVAC components such as Air Handling Units, Fan Coil Units, Roof Top Units, Chiller Units, and Air Conditioning devices through its 48 certification programs.

Air handling units are composed of components such as fans, water coils, heat recovery exchangers, filters, and humidifiers, brought together in different configurations. These components are placed inside a casing that possesses heat and sound insulation. The EUROVENT Certification program classifies the casing of the air handling unit according to the EN 1886 standard and approves thermal, acoustic, and electrical values in the data sheet created by the configuration and selection software by testing them according to EN 13053 standard.

According to EN 1886, the acoustic absorption, thermal bridging value, heat transfer coefficient, leakage values under negative and positive pressure, and deflection of the casing named MODEL BOX are measured. In EN 13053 tests, units' performance values are measured and compared with the selection data sheet. Additionally, the energy label value of the unit provided in the selection software is also approved.



VDI 6022 HYGIENE CERTIFICATION

Air handling units are designed and produced to introduce conditioned clean air into the indoor environment. Due to temperature differences

between the indoor and outdoor environments and the characteristics of the transferred air, bacteria and mold formation are observed in points where maintenance is not possible if the correct components are not used or due to errors in unit design. Especially since the 1980s, for air conditioning systems, to prevent the formation of bacteria causing Legionnaires' disease, all components except those made of metal inside the device need to be observed with the ISO 846 test for the absence of bacteria or mold formation. The German Engineers Association (VDI) guarantees safety of air handling units with VDI 6022 standard, which specifies hygiene conditions in air handling units, and does this through a certification program. During the certification process, while the components found inside the air handling units are approved against bacteria and mold formation with ISO 846 test, the body of the air handling unit is also tested and certified based on measures taken for cleanliness and removal of condensation.

AERA Compact air handling units have completed this certification process and have earned the VDI 6022 Hygiene certificate.

AERA Compact air handling units can be selected on www.aerselect.com and AERA Modular Air Handling Units can be selected through AERA Modular AHU Selection software; both have been verified as a result of tests conducted by EUROVENT. Moreover, all the Model Boxes in AERA's product portfolio have been tested according to EN 1886 and their performances have been documented.

AERA Compact air handling units have completed this certification process and have earned the VDI 6022 Hygiene certificate.

EVO-POOL

POOL DEHUMIDIFICATION UNIT

High efficient dehumidification units are important in places such as pool areas which has high amount of evaporating water. EVOPOOL units with their high humidification capacity create a comfortable environment and also protect the building from corrosion.

EVOPOOL units are designed to be used for dehumidification process of swimming pools according to the calculated conditions of the pools. Dehumidification efficiency is maximized by hermetic scroll compressors with high COP.

EVOPOOL units are equipped with SENSOPOOL control system as standard.

SENSOPOOL is designed specially for these units and has different intelligent energy efficient modes based on occupancy and outdoor enthaply.

EC type plug fans with high corrosion resistance impellers are used in EVOPOOL units.

EC Fans don't require frequency inverters and always ensures high efficiency operation. SENSOPOOL controls provides constant airflow mode as standard.





CASING

EVOPOOL Unit's casings are engineered with today's standards, according to future needs. By eliminating the defects of traditional casings, high thermal and acoustical performance have been achieved, mechanical strength and corrosion resistance have been increased. As a result, a compact body that provides easy operation and service has emerged.

EVAPORATOR

In the units, direct expansion type coils are used in order to obtain the humidity of the return air. Evaporator carry the air taken from indoor to the dew point to 100% relative humidity curve and reduce the absolute humidity by condensing. Evaporator is produced with epoxy paint against corrosion and special structure for easy discharge of condensate.

COMPRESSORS

High efficiency, hermetic scroll type, working with R407C gas compressors are used in units. All cooling circuit and control equipments are implemented in the system and system security is ensured.

CONDENSER

Before dehumidified cold air being blown into the interior it is providing heating via waste heat of cooling cycle.

PLATE HEAT EXCHANGER

It collects energy from the extract air and transfers it to supply air. Return and fresh air fully separated from each other, only heat transfer happens. Plate heat recovery is coated with epoxy paint against corrosion.

EXTRACT AND FRESH AIR FANS

High electrical and aerodynamic efficiency, self-propelled, backward curved blade, EC fans or AC fans are used. Motors are protected against high electric current and mechanical obstruction and have constant flow control with SENSOPOOL. The body of fans is made of aluminum alloy sheet metal with high corrosion resistance.



FILTRATION

The units are equipped with coarse 90% and epm1 55% (G4+F7) class filters on the fresh air side and coarse 90% (G4) class filters on the exhaust side

SENSOPOOL

EVOPOOL units are shipped with SENSOPOOL controls as standard. The SENSOPOOL control board automatically regulates extract and fresh air fans, safety and control of refrigeration cycle, the damper automation. With the control panel, the user can control the unit up to 200 meters distance with a wired control, weekly time program, filter pollution, operation/alarm control.



Calculating Steam Amount in Pools (according to VDI 2089)

Covered pools can have different temperatures according to their purpose of use. For their purposes of use, the average of comfortness conditions are provided situations values are given in the table below.

Purpose of Use	Indoor Temperature	Pool Water Temperature
Fun Pools	24-29 °C	24-29 °C
Sports Pools	26-29 °C	24-28 °C
Hotel Pools	28-29 °C	28-30 °C
Spas	27-29 °C	36-40 °C

Pools based on their usage are classified as follows and calculations are made according to activity factor.

Application	"Activity Factor, E gxm-2xh-1xmbar-1"
Covered Pools	0,5
Stationary Pools (Out of Service)	5
Residential Pools	15
Public Pools	20
Fun Pools	28
Undulating, waterslide etc. The pools include equipments	35

Steaming Amount : $W=ExAx(P_W-P_R)$

E= Pool Activity Factor

A= Pool Area

P_W =At pool water temperature saturated air's steam pressure (%100RH)

P_R =Desired air's steam pressure indoor

Calculating Example

Pool Area : 154 m²

Purpose of use : Hotel Pool

Pool Water Temperature : 28 °C

Indoor Conditions : 30 °C, %60 RH

Calculating Steam Pressure Values

P_W :8 °C, %100 RH steam pressure, 37.78 mbar

P_R :30 °C, %60 RH steam pressure, 25.45 mbar

Activity Factor, Public Pool; 20 gxm-2xh-1xmbar-1

$W=ExAx(P_W-P_R)$

$W=20 \times 154 \times (37.78-25.45)$

Calculated as $W = 41056 \text{ g/h}=41.1 \text{ l/h}$.

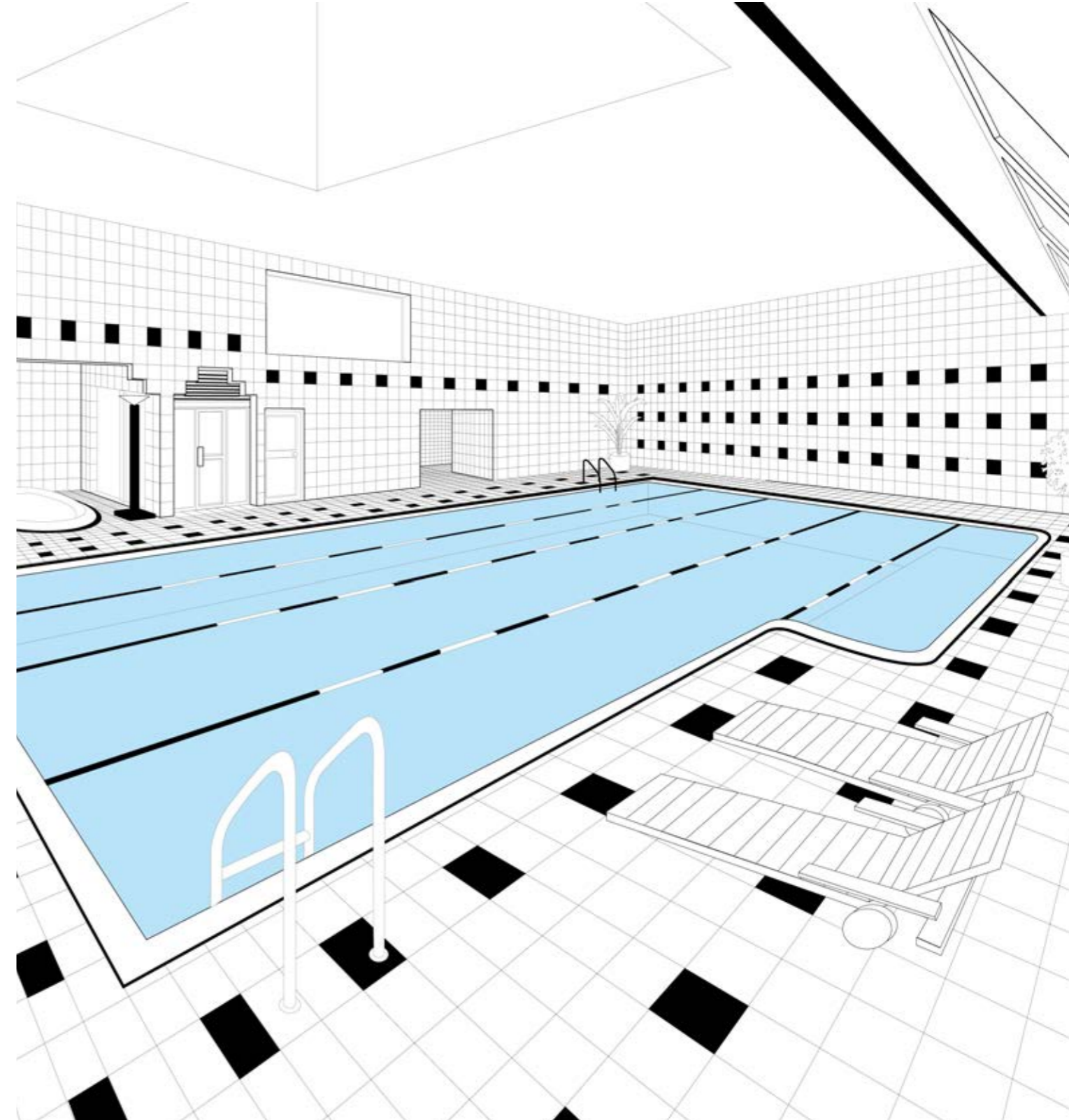

High efficient dehumidification units are important in places such as pool areas which has high amount of evaporating water. EVOPOOL units with their high humidification capacity create a comfortable environment and also protect the building from corrosion.

■ EVO POOL 30



UNIT INFORMATION

EVO POOL 30	
Exchanger Type	Aluminum Plate Cross Flow
Fan Type	EC Plug Fan
Installation	Indoor / Outdoor (3)
Installation Position	Vertical
Service Location	Front surface (4)
Case structure	50 mm Insulated Double Walled

TECHNICAL INFORMATIONS

Nominal Air Flow Ratio (m3/h)	3000
Total Dehumidification Capacity (kg/h)	19
Case features according to EN 1886	D1/L1/TB2/T2
Fresh Air Front Filter	Coarse (G4)
Fresh air Filter	ePM1 55% (F7)
Exhaust Filter	Coarse (G4)
Operating Temperature (1) (°C)	-20/+50
Protection Class	IP 31

Electrical Informations	
Communicating Informations	BACnet, Modbus TCP/IP
Supply Voltage	400V, 3~, 50 Hz
Total Power (1) (kW)	7,85
Maksimum Current (A)	15,43
Sound Information (2)	
Sound Level at Supply (dBA)	81
Sound Level at Return (dBA)	73
Surrounding Sound 1m. Distance (dBA)	54
Surrounding Sound 3m. Distance (dBA)	45
Surrounding Sound 5m. Distance (dBA)	40

■ DIMENSIONS [mm]

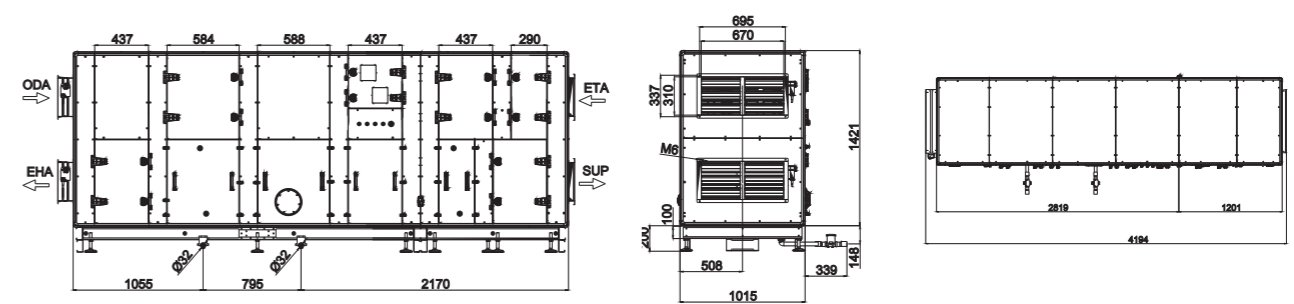

ACCESSORIES

Electric Pre Heater	Optional	Internal of device	Page 26
Electric After Heater	Optional	Internal of device	Page 26
Water After Heater	Standard		
Water Cooler	-	-	-
Duct Connection Damper	Optional		Page 27
Outside Protection Sheet	-		-
Fresh Air Spigot	-		-
Exhaust Spigot	-		-
Drainage Pump	-		-
Bulk Siphon	Standard		-
Room Control Panel Type1	EVO ECO		Page 29
Room Control Panel Type2	EVO TOUCH		Page 29
Room Control Panel Type3	-		-
Cloud Connections Right	-		-
VOD Sensor CO2	Standard		-
VOD Sensor RH%	Optional		Page 28
VOD Sensor VOC	Optional		Page 28
Signal Converter	Optional		Page 29
Constant Pressure Kit	-		-

- (1) Together with Electrical Preheater
- (2) As a result of the measurement according to ISO 5136
- (3) Outside Kit is used
- (4) Bidirectional installation is provided via service covers located at front and back
- (5) Humidity transfer is possible with the selection of Adsorption Rotor

■ EVO POOL 50



UNIT INFORMATION

	EVO POOL 50
Exchanger Type	Aluminum Plate Cross Flow
Fan Type	EC Plug Fan
Installation	Indoor / Outdoor (3)
Installation Position	Vertical
Service Location	Front surface (4)
Case structure	50 mm Insulated Double Walled

TECHNICAL INFORMATIONS

Nominal Air Flow Ratio (m3/h)	5000
Total Dehumidification Capacity (kg/h)	31
Case features according to EN 1886	D1/L1/TB2/T2
Fresh Air Front Filter	Coarse (G4)
Fresh air Filter	ePM1 55% (F7)
Exhaust Filter	Coarse (G4)
Operating Temperature (1) (°C)	-20/+50
Protection Class	IP 31

Electrical Informations

Communicating Informations	BACnet, Modbus TCP/IP
Supply Voltage	400V, 3~, 50 Hz
Total Power (1) (kW)	11,76
Maksimum Current (A)	22,47

Sound Information (2)

Sound Level at Supply (dBA)	75
Sound Level at Return (dBA)	65
Surrounding Sound 1m. Distance (dBA)	49
Surrounding Sound 3m. Distance (dBA)	40
Surrounding Sound 5m. Distance (dBA)	35

■ DIMENSIONS [mm]

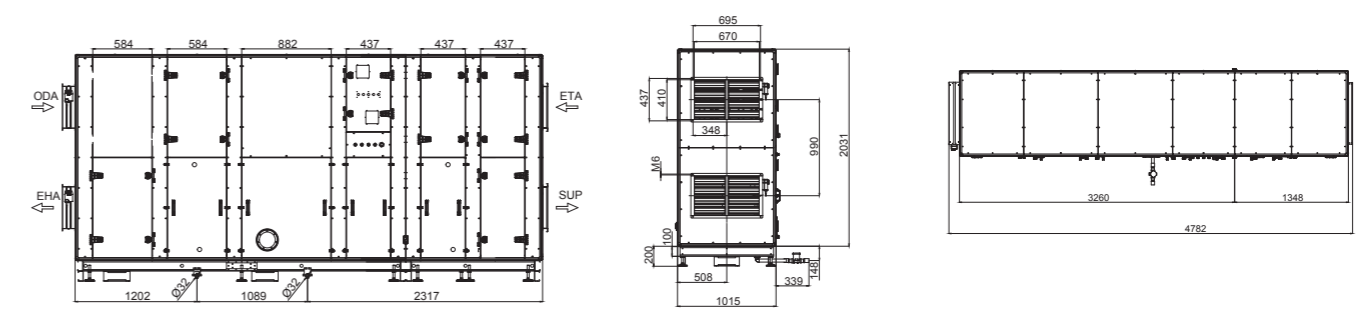

ACCESSORIES

Electric Pre Heater	Optional	Internal of device	Page 26
Electric After Heater	Optional	Internal of device	Page 26
Water After Heater	Standard		
Water Cooler	-	-	-
Duct Connection Damper	Optional		Page 27
Outside Protection Sheet	-	-	
Fresh Air Spigot	-	-	
Exhaust Spigot	-	-	
Drainage Pump	-	-	
Bulk Siphon	Standard	-	
Room Control Panel Type1	EVO ECO		Page 29
Room Control Panel Type2	EVO TOUCH		Page 29
Room Control Panel Type3	-	-	
Cloud Connections Right	-	-	
VOD Sensor CO2	Standard		
VOD Sensor RH%	Optional		Page 28
VOD Sensor VOC	Optional		Page 28
Signal Converter	Optional		Page 29
Constant Pressure Kit	-	-	

- (1) Together with Electrical Preheater
- (2) As a result of the measurement according to ISO 5136
- (3) Outside Kit is used
- (4) Bidirectional installation is provided via sevice covers located at front and back
- (5) Humidity transfer is possible with the selection of Adsorption Rotor

■ EVO POOL 70



UNIT INFORMATION

EVO POOL 70	
Exchanger Type	Aluminum Plate Cross Flow
Fan Type	EC Plug Fan
Installation	Indoor / Outdoor (3)
Installation Position	Vertical
Service Location	Front surface (4)
Case structure	50 mm Insulated Double Walled

TECHNICAL INFORMATIONS

Nominal Air Flow Ratio (m ³ /h)	7000
Total Dehumidification Capacity (kg/h)	44
Case features according to EN 1886	D1/L1/TB2/T2
Fresh Air Front Filter	Coarse (G4)
Fresh air Filter	ePM1 55% (F7)
Exhaust Filter	Coarse (G4)
Operating Temperature (1) (°C)	-20/+50
Protection Class	IP 31

Electrical Informations	
Communicating Informations	BACnet, Modbus TCP/IP
Supply Voltage	400V, 3~, 50 Hz
Total Power (1) (kW)	15,76
Maksimum Current (A)	30,94
Sound Information (2)	
Sound Level at Supply (dBA)	78
Sound Level at Return (dBA)	68
Surrounding Sound 1m. Distance (dBA)	52
Surrounding Sound 3m. Distance (dBA)	43
Surrounding Sound 5m. Distance (dBA)	38

■ DIMENSIONS [mm]

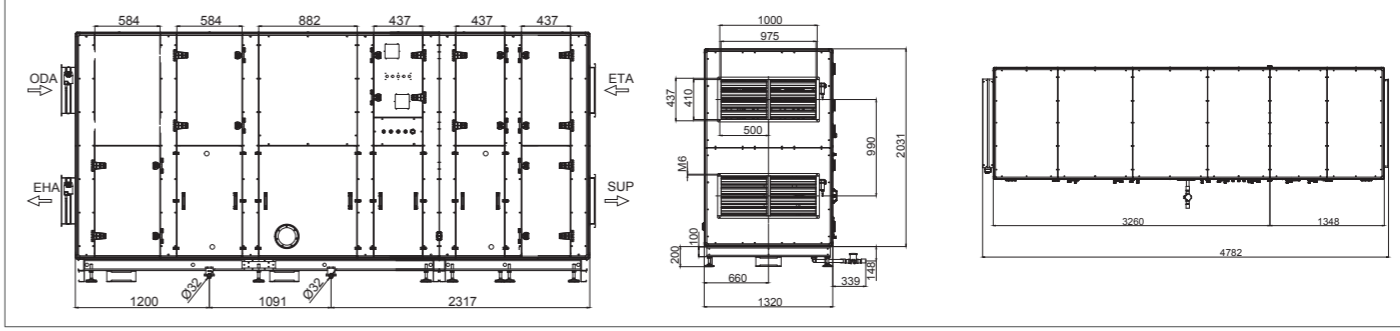

ACCESSORIES

Electric Pre Heater	Optional	Internal of device	Page 26
Electric After Heater	Optional	Internal of device	Page 26
Water After Heater	Standard		
Water Cooler	-	-	-
Duct Connection Damper	Optional		Page 27
Outside Protection Sheet	-	-	
Fresh Air Spigot	-	-	
Exhaust Spigot	-	-	
Drainage Pump	-	-	
Bulk Siphon	Standard	-	
Room Control Panel Type1	EVO ECO		Page 29
Room Control Panel Type2	EVO TOUCH		Page 29
Room Control Panel Type3	-	-	
Cloud Connections Right	-	-	
VOD Sensor CO2	Standard		
VOD Sensor RH%	Optional		Page 28
VOD Sensor VOC	Optional		Page 28
Signal Converter	Optional		Page 29
Constant Pressure Kit	-	-	

- (1) Together with Electrical Preheater
- (2) As a result of the measurement according to ISO 5136
- (3) Outside Kit is used
- (4) Bidirectional installation is provided via service covers located at front and back
- (5) Humidity transfer is possible with the selection of Adsorption Rotor

■ EVO POOL 100



UNIT INFORMATION

	EVO POOL 100
Exchanger Type	Aluminum Plate Cross Flow
Fan Type	EC Plug Fan
Installation	Indoor / Outdoor (3)
Installation Position	Vertical
Service Location	Front surface (4)
Case structure	50 mm Insulated Double Walled

TECHNICAL INFORMATIONS

Nominal Air Flow Ratio (m3/h)	10000
Total Dehumidification Capacity (kg/h)	63
Case features according to EN 1886	D1/L1/TB2/T2
Fresh Air Front Filter	Coarse (G4)
Fresh air Filter	ePM1 55% (F7)
Exhaust Filter	Coarse (G4)
Operating Temperature (1) (°C)	-20/+50
Protection Class	IP 31

Electrical Informations	
Communicating Informations	BACnet, Modbus TCP/IP
Supply Voltage	400V, 3~, 50 Hz
Total Power (1) (kW)	22,21
Maksimum Current (A)	41,01
Sound Information (2)	
Sound Level at Supply (dBA)	80
Sound Level at Return (dBA)	69
Surrounding Sound 1m. Distance (dBA)	54
Surrounding Sound 3m. Distance (dBA)	45
Surrounding Sound 5m. Distance (dBA)	40

■ DIMENSIONS [mm]

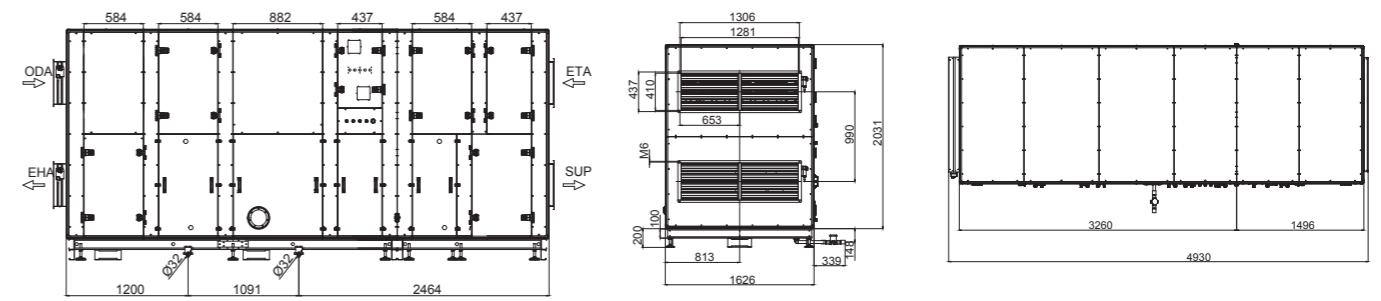

ACCESSORIES

Electric Pre Heater	Optional	Internal of device	Page 26
Electric After Heater	Optional	Internal of device	Page 26
Water After Heater	Standard		
Water Cooler	-	-	-
Duct Connection Damper	Optional		Page 27
Outside Protection Sheet	-	-	
Fresh Air Spigot	-	-	
Exhaust Spigot	-	-	
Drainage Pump	-	-	
Bulk Siphon	Standard		
Room Control Panel Type1	EVO ECO		Page 29
Room Control Panel Type2	EVO TOUCH		Page 29
Room Control Panel Type3	-	-	
Cloud Connections Right	-	-	
VOD Sensor CO2	Standard		
VOD Sensor RH%	Optional		Page 28
VOD Sensor VOC	Optional		Page 28
Signal Converter	Optional		Page 29
Constant Pressure Kit	-	-	

- (1) Together with Electrical Preheater
- (2) As a result of the measurement according to ISO 5136
- (3) Outside Kit is used
- (4) Bidirectional installation is provided via service covers located at front and back
- (5) Humidity transfer is possible with the selection of Adsorption Rotor

■ EVO POOL 120



UNIT INFORMATION

	EVO POOL 120
Exchanger Type	Aluminum Plate Cross Flow
Fan Type	EC Plug Fan
Installation	Indoor / Outdoor (3)
Installation Position	Vertical
Service Location	Front surface (4)
Case structure	50 mm Insulated Double Walled

TECHNICAL INFORMATIONS

Nominal Air Flow Ratio (m3/h)	12000
Total Dehumidification Capacity (kg/h)	76
Case features according to EN 1886	D1/L1/TB2/T2
Fresh Air Front Filter	Coarse (G4)
Fresh air Filter	ePM1 55% (F7)
Exhaust Filter	Coarse (G4)
Operating Temperature (1) (°C)	-20/+50
Protection Class	IP 31

Electrical Informations	
Communicating Informations	BACnet, Modbus TCP/IP
Supply Voltage	400V, 3~, 50 Hz
Total Power (1) (kW)	27,57
Maksimum Current (A)	47,48
Sound Information (2)	
Sound Level at Supply (dBA)	79
Sound Level at Return (dBA)	70
Surrounding Sound 1m. Distance (dBA)	54
Surrounding Sound 3m. Distance (dBA)	44
Surrounding Sound 5m. Distance (dBA)	40

■ DIMENSIONS [mm]

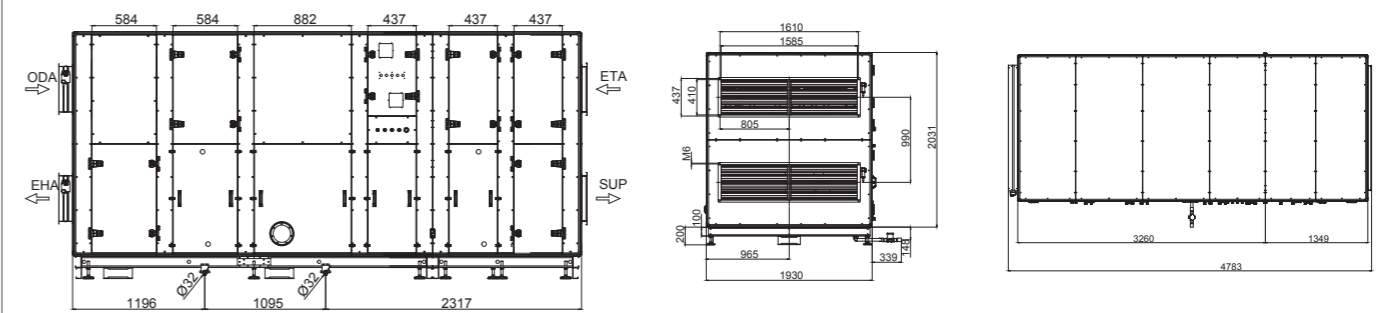

ACCESSORIES

Electric Pre Heater	Optional	Internal of device	Page 26
Electric After Heater	Optional	Internal of device	Page 26
Water After Heater	Standard		
Water Cooler	-	-	-
Duct Connection Damper	Optional		Page 27
Outside Protection Sheet	-	-	
Fresh Air Spigot	-	-	
Exhaust Spigot	-	-	
Drainage Pump	-	-	
Bulk Siphon	Standard	-	
Room Control Panel Type1	EVO ECO		Page 29
Room Control Panel Type2	EVO TOUCH		Page 29
Room Control Panel Type3	-	-	
Cloud Connections Right	-	-	
VOD Sensor CO2	Standard		
VOD Sensor RH%	Optional		Page 28
VOD Sensor VOC	Optional		Page 28
Signal Converter	Optional		Page 29
Constant Pressure Kit	-	-	

- (1) Together with Electrical Preheater
- (2) As a result of the measurement according to ISO 5136
- (3) Outside Kit is used
- (4) Bidirectional installation is provided via service covers located at front and back
- (5) Humidity transfer is possible with the selection of Adsorption Rotor

■ EVO POOL 150



UNIT INFORMATION

	EVO POOL 150
Exchanger Type	Aluminum Plate Cross Flow
Fan Type	EC Plug Fan
Installation	Indoor / Outdoor (3)
Installation Position	Vertical
Service Location	Front surface (4)
Case structure	50 mm Insulated Double Walled

TECHNICAL INFORMATIONS

Nominal Air Flow Ratio (m3/h)	15000
Total Dehumidification Capacity (kg/h)	95
Case features according to EN 1886	D1/L1/TB2/T2
Fresh Air Front Filter	Coarse (G4)
Fresh air Filter	ePM1 55% (F7)
Exhaust Filter	Coarse (G4)
Operating Temperature (1) (°C)	-20/+50
Protection Class	IP 31

Electrical Informations	
Communicating Informations	BACnet, Modbus TCP/IP
Supply Voltage	400V, 3~, 50 Hz
Total Power (1) (kW)	33,01
Maksimum Current (A)	66,52
Sound Information (2)	
Sound Level at Supply (dBA)	82
Sound Level at Return (dBA)	74
Surrounding Sound 1m. Distance (dBA)	57
Surrounding Sound 3m. Distance (dBA)	47
Surrounding Sound 5m. Distance (dBA)	43

■ DIMENSIONS [mm]

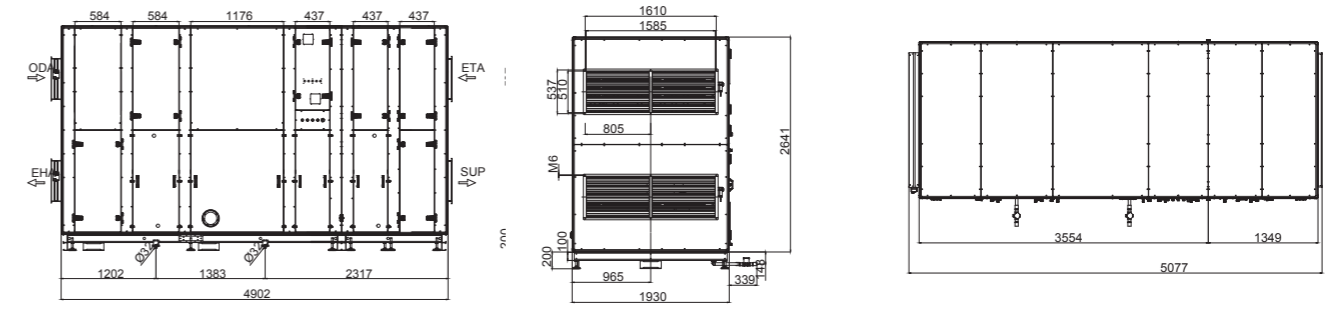

ACCESSORIES

Electric Pre Heater	Optional	Internal of device	Page 26
Electric After Heater	Optional	Internal of device	Page 26
Water After Heater	Standard		
Water Cooler	-	-	-
Duct Connection Damper	Optional		Page 27
Outside Protection Sheet	-	-	
Fresh Air Spigot	-	-	
Exhaust Spigot	-	-	
Drainage Pump	-	-	
Bulk Siphon	Standard		
Room Control Panel Type1	EVO ECO		Page 29
Room Control Panel Type2	EVO TOUCH		Page 29
Room Control Panel Type3	-	-	
Cloud Connections Right	-	-	
VOD Sensor CO2	Standard		
VOD Sensor RH%	Optional		Page 28
VOD Sensor VOC	Optional		Page 28
Signal Converter	Optional		Page 29
Constant Pressure Kit	-	-	

- (1) Together with Electrical Preheater
- (2) As a result of the measurement according to ISO 5136
- (3) Outside Kit is used
- (4) Bidirectional installation is provided via service covers located at front and back
- (5) Humidity transfer is possible with the selection of Adsorption Rotor

■ EVO POOL 200



UNIT INFORMATION

	EVO POOL 200
Exchanger Type	Aluminum Plate Cross Flow
Fan Type	EC Plug Fan
Installation	Indoor / Outdoor (3)
Installation Position	Vertical
Service Location	Front surface (4)
Case structure	50 mm Insulated Double Walled

TECHNICAL INFORMATIONS

Nominal Air Flow Ratio (m3/h)	20000
Total Dehumidification Capacity (kg/h)	127
Case features according to EN 1886	D1/L1/TB2/T2
Fresh Air Front Filter	Coarse (G4)
Fresh air Filter	ePM1 55% (F7)
Exhaust Filter	Coarse (G4)
Operating Temperature (1) (°C)	-20/+50
Protection Class	IP 31

Electrical Informations	
Communicating Informations	BACnet, Modbus TCP/IP
Supply Voltage	400V, 3~, 50 Hz
Total Power (1) (kW)	45,37
Maksimum Current (A)	82,02
Sound Information (2)	
Sound Level at Supply (dBA)	85
Sound Level at Return (dBA)	78
Surrounding Sound 1m. Distance (dBA)	61
Surrounding Sound 3m. Distance (dBA)	51
Surrounding Sound 5m. Distance (dBA)	47

■ DIMENSIONS [mm]

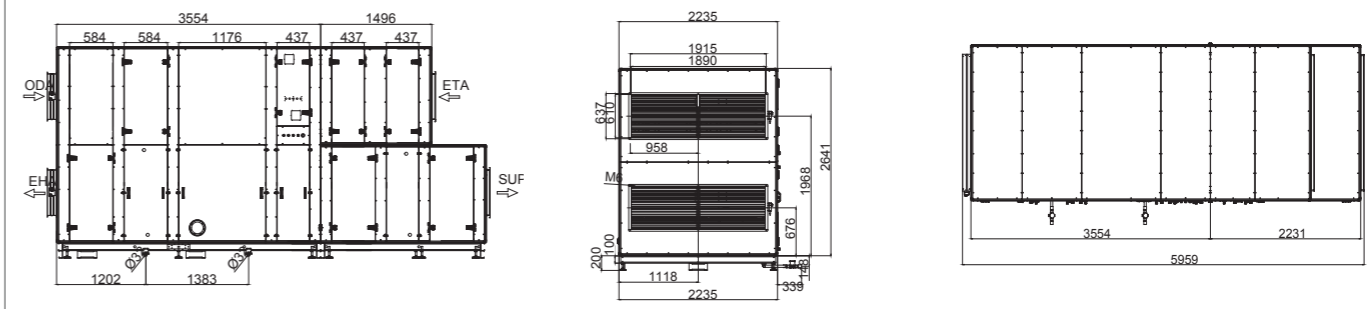

ACCESSORIES

Electric Pre Heater	Optional	Internal of device	Page 26
Electric After Heater	Optional	Internal of device	Page 26
Water After Heater	Standard		
Water Cooler	-	-	-
Duct Connection Damper	Optional		Page 27
Outside Protection Sheet	-	-	
Fresh Air Spigot	-	-	
Exhaust Spigot	-	-	
Drainage Pump	-	-	
Bulk Siphon	Standard	-	
Room Control Panel Type1	EVO ECO		Page 29
Room Control Panel Type2	EVO TOUCH		Page 29
Room Control Panel Type3	-	-	
Cloud Connections Right	-	-	
VOD Sensor CO2	Standard		
VOD Sensor RH%	Optional		Page 28
VOD Sensor VOC	Optional		Page 28
Signal Converter	Optional		Page 29
Constant Pressure Kit	-	-	

- (1) Together with Electrical Preheater
- (2) As a result of the measurement according to ISO 5136
- (3) Outside Kit is used
- (4) Bidirectional installation is provided via service covers located at front and back
- (5) Humidity transfer is possible with the selection of Adsorption Rotor

■ EVO POOL 250



UNIT INFORMATION

	EVO POOL 250
Exchanger Type	Aluminum Plate Cross Flow
Fan Type	EC Plug Fan
Installation	Indoor / Outdoor (3)
Installation Position	Vertical
Service Location	Front surface (4)
Case structure	50 mm Insulated Double Walled

TECHNICAL INFORMATIONS

Nominal Air Flow Ratio (m3/h)	25000
Total Dehumidification Capacity (kg/h)	159
Case features according to EN 1886	D1/L1/TB2/T2
Fresh Air Front Filter	Coarse (G4)
Fresh air Filter	ePM1 55% (F7)
Exhaust Filter	Coarse (G4)
Operating Temperature (1) (°C)	-20/+50
Protection Class	IP 31

Electrical Informations	
Communicating Informations	BACnet, Modbus TCP/IP
Supply Voltage	400V, 3~, 50 Hz
Total Power (1) (kW)	56,04
Maksimum Current (A)	98,44
Sound Information (2)	
Sound Level at Supply (dBA)	85
Sound Level at Return (dBA)	79
Surrounding Sound 1m. Distance (dBA)	63
Surrounding Sound 3m. Distance (dBA)	53
Surrounding Sound 5m. Distance (dBA)	50

■ DIMENSIONS [mm]

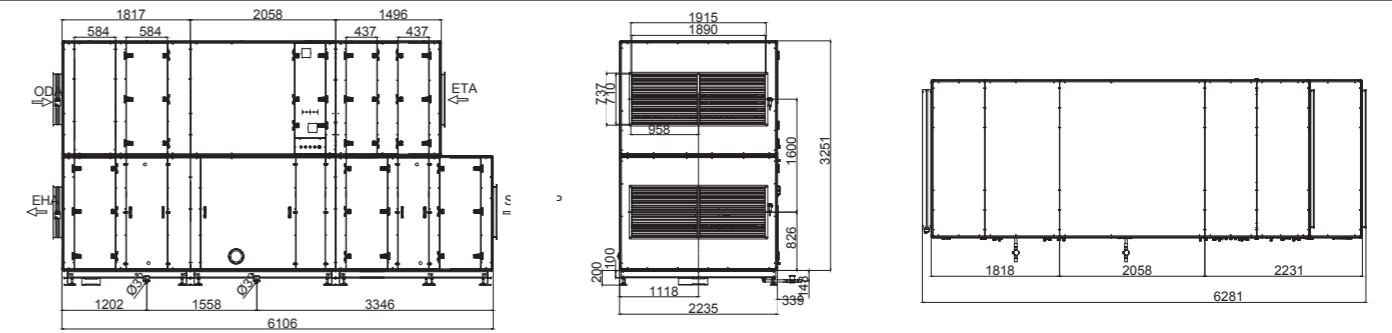

ACCESSORIES

Electric Pre Heater	Optional	Internal of device	Page 26
Electric After Heater	Optional	Internal of device	Page 26
Water After Heater	Standard		
Water Cooler	-	-	-
Duct Connection Damper	Optional		Page 27
Outside Protection Sheet	-		-
Fresh Air Spigot	-		-
Exhaust Spigot	-		-
Drainage Pump	-		-
Bulk Siphon	Standard		-
Room Control Panel Type1	EVO ECO		Page 29
Room Control Panel Type2	EVO TOUCH		Page 29
Room Control Panel Type3	-		-
Cloud Connections Right	-		-
VOD Sensor CO2	Standard		
VOD Sensor RH%	Optional		Page 28
VOD Sensor VOC	Optional		Page 28
Signal Converter	Optional		Page 29
Constant Pressure Kit	-		-

- (1) Together with Electrical Preheater
- (2) As a result of the measurement according to ISO 5136
- (3) Outside Kit is used
- (4) Bidirectional installation is provided via service covers located at front and back
- (5) Humidity transfer is possible with the selection of Adsorption Rotor

■ EVO POOL 300



UNIT INFORMATION

	EVO POOL 300
Exchanger Type	Aluminum Plate Cross Flow
Fan Type	EC Plug Fan
Installation	Indoor / Outdoor (3)
Installation Position	Vertical
Service Location	Front surface (4)
Case structure	50 mm Insulated Double Walled

TECHNICAL INFORMATIONS

Nominal Air Flow Ratio (m3/h)	30000
Total Dehumidification Capacity (kg/h)	190
Case features according to EN 1886	D1/L1/TB2/T2
Fresh Air Front Filter	Coarse (G4)
Fresh air Filter	ePM1 55% (F7)
Exhaust Filter	Coarse (G4)
Operating Temperature (1) (°C)	-20/+50
Protection Class	IP 31

Electrical Informations	
Communicating Informations	BACnet, Modbus TCP/IP
Supply Voltage	400V, 3~, 50 Hz
Total Power (1) (kW)	67,41
Maksimum Current (A)	123,03
Sound Information (2)	
Sound Level at Supply (dBA)	88
Sound Level at Return (dBA)	83
Surrounding Sound 1m. Distance (dBA)	69
Surrounding Sound 3m. Distance (dBA)	58
Surrounding Sound 5m. Distance (dBA)	51

■ DIMENSIONS [mm]

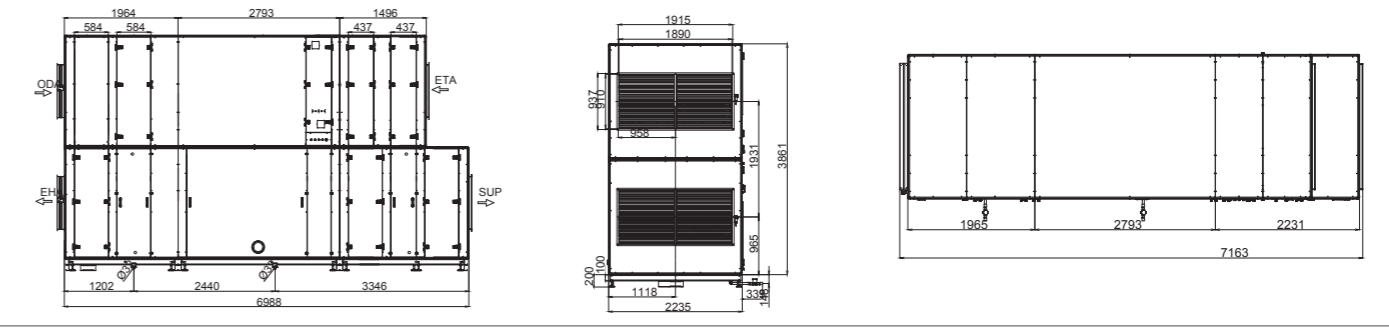

ACCESSORIES

Electric Pre Heater	Optional	Internal of device	Page 26
Electric After Heater	Optional	Internal of device	Page 26
Water After Heater	Standard		
Water Cooler	-	-	-
Duct Connection Damper	Optional		Page 27
Outside Protection Sheet	-		-
Fresh Air Spigot	-		-
Exhaust Spigot	-		-
Drainage Pump	-		-
Bulk Siphon	Standard		-
Room Control Panel Type1	EVO ECO		Page 29
Room Control Panel Type2	EVO TOUCH		Page 29
Room Control Panel Type3	-		-
Cloud Connections Right	-		-
VOD Sensor CO2	Standard		-
VOD Sensor RH%	Optional		Page 28
VOD Sensor VOC	Optional		Page 28
Signal Converter	Optional		Page 29
Constant Pressure Kit	-		-

- (1) Together with Electrical Preheater
- (2) As a result of the measurement according to ISO 5136
- (3) Outside Kit is used
- (4) Bidirectional installation is provided via service covers located at front and back
- (5) Humidity transfer is possible with the selection of Adsorption Rotor

ACCESSORIES

■ ELECTRICAL PREHEATER

Used in order to prevent freezing at the exchanger in the situations which the outside air is very low. Controlled as a single step with SENSO control. Provides controllable energy efficiency with SENSO+ control via proportional signal.

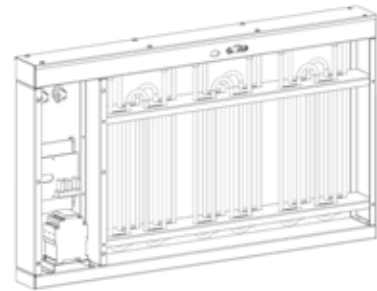

Model	Heater Capacity (kW)	Current (A)	Control
EP-PREH 30	9	13	Oransal
EP-PREH 50	12	17,3	Oransal
EP-PREH 70	15	21,7	Oransal
EP-PREH 100	24	34,7	Oransal
EP-PREH 120	24	34,7	Oransal
EP-PREH 150	30	43,3	Oransal
EP-PREH 180	30	43,3	Oransal
EP-PREH 200	48	69,3	Oransal
EP-PREH 250	48	69,3	Oransal
EP-PREH 300	60	86,7	Oransal

■ ELECTRICAL AFTER HEATER

Used for increasing the supply air temperature. Operates automatically according to desired room temperature or desired supply temperature. Controlled as a single step with SENSO control. Provides controllable energy efficiency with SENSO+ control via proportional signal.

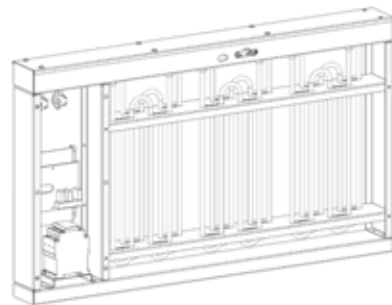

Model	Heater Capacity (kW)	Current (A)	Control
EP-POEH 30	9	13	Oransal
EP-POEH 50	12	17,3	Oransal
EP-POEH 70	15	21,7	Oransal
EP-POEH 100	24	34,7	Oransal
EP-POEH 120	24	34,7	Oransal
EP-POEH 150	30	43,3	Oransal
EP-POEH 180	30	43,3	Oransal
EP-POEH 200	48	69,3	Oransal
EP-POEH 250	48	69,3	Oransal
EP-POEH 300	60	86,7	Oransal

■ WATER AFTER HEATER

Used for increasing the supply air temperature. Operates automatically according to desired room temperature or desired supply temperature. Controlled as a single step with SENSO control. Provides controllable energy efficiency with SENSO+ control via proportional signal.

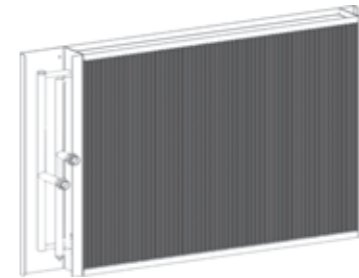

Model	Heater Capacity (kW)	Water Regime	Control
EP-POWH 30	9	80-60	Oransal
EP-POWH 50	12	80-60	Oransal
EP-POWH 70	15	80-60	Oransal
EP-POWH 100	24	80-60	Oransal
EP-POWH 120	24	80-60	Oransal
EP-POWH 150	30	80-60	Oransal
EP-POWH 180	30	80-60	Oransal
EP-POWH 200	48	80-60	Oransal
EP-POWH 250	48	80-60	Oransal
EP-POWH 300	60	80-60	Oransal

■ Duct Connection Damper

The motor operated damper, as turned itself off when the devices is turned off, prevent the leakage can be occurred via air duct. It can be implemented in or out of device. Has the Class 3 impermability as a standard.

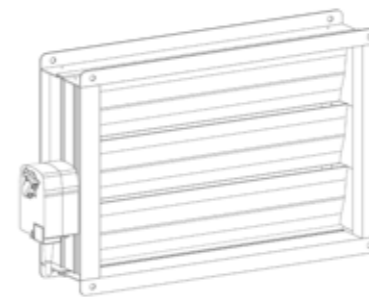

Model	Heater Capacity (kW)	Current (A)
EP-DAMP 30	40...75 s	24C DC, spring return
EP-DAMP 50	40...75 s	24C DC, spring return
EP-DAMP 70	40...75 s	24C DC, spring return
EP-DAMP 100	40...75 s	24C DC, spring return
EP-DAMP 120	40...75 s	24C DC, spring return
EP-DAMP 150	40...75 s	24C DC, spring return
EP-DAMP 180	40...75 s	24C DC, spring return
EP-DAMP 200	40...75 s	24C DC, spring return
EP-DAMP 250	40...75 s	24C DC, spring return
EP-DAMP 300	40...75 s	24C DC, spring return

ACCESSORIES

■ Outdoor Protection Sheet

If the devices are used outdoors, they are used for water insulation. The devices thus achieve the insulation class IP 54.



Model

EP-WPC 30

EP-WPC 50

EP-WPC 70

EP-WPC 100

EP-WPC 120

EP-WPC 150

EP-WPC 180

EP-WPC 200

EP-WPC 250

■ VOD

Located in inside of critical volume or return duct, the optional air quality sensor (VOC or CO₂) or relative humidity sensor (RH%) consistently measures the air quality or relative humidity. This value, as being compared with set value which is arranged on control, creates operating which changes EC fan's fan speed. If the air in room is lower than desired air quality or the relative humidity is higher than the desired value, the fan speed is increased so, fresh air amount increased, if the air in room is higher than desired air quality or the relative humidity is lower than the desired value, the fan speed is decreased so, fresh air amount decreased; Thus, a significant energy save is provided at the heating or cooling loads caused by the fresh air.



Model	Measurement	Installation Position
VOD-VOC-RM	VOC	Room
VOD-VOC-DUCT	VOC	Channel
VOD-CO ₂ -DUCT	CO ₂	Room
VOD-CO ₂ -RM	CO ₂	Channel
VOD-RH-DUCT	RH%	Room
VOD-RH-RM	RH%	Channel
PS-MW	-	-

■ Signal Converter

SENSO+ devices as make an access that connect up to 3 VOD sensors, both measure gas and different volume gases, change the capacity according to these measurements of air conditioning plants. Via Signal Converter, in 3 different types, for each type up to 6 measurements or obtained values from 18 different measurement volumes are used for controlling air conditioning plant is provided.



Model

SENSO+ SK

■ EVO-ECO

Is a user panel used as a user interface in the devices has the SENSO+ control card. Connected to control panel via 4x0.75 cable or RJ-12 Jack.



Model

EVO-ECO

■ EVO-TOUCH

Is a 7" sized touch type user panel used as a user interface. Connected to control panel via 4x0.75 cable or RJ-12 Jack.



Model

EVO-TOUCH



**AERA Air Conditioning
Ventilation**

Factory I: İGİS Cooperatif, Pancar OSB
Factory II: 3. Cadde, No:13, Pancar OSB
Torbali/İzmir-Türkiye, +90 232 799 01 11
E-mail: sales@aera.com.tr

Sales Headoffice: Özdemir Sok. Kurtuluş Apt.
No: 5
Kadıköy/İstanbul-Türkiye, +90 216 504 76 86



**aera.com.
tr**